

PROOFER CABINETS AVANT

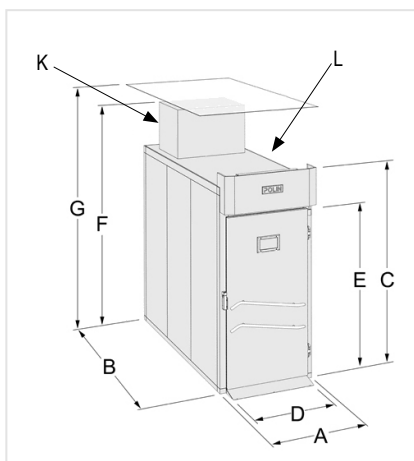

(C) 2520 mm - (F) 3100 mm
 (G) 3100 mm - (E) 2000 mm

TECHNICAL SPECIFICATIONS FOR INSTALLATION

MINIMUM WIDTH = A + 50 mm / MINIMUM DEPTH = B + 100 mm
 MINIMUM HEIGHT FOR INSTALLATION = PLEASE SEE BOTTOM OF THE DRAWING

K = PLACEMENT OF THE WATER OUTLET AND INLET DUCTS

WATER INLET

HEIGHT: 250 cm

SECTION: 1/2 WITH BALL VALVE AND PRESSURE REDUCER

WATER OUTLET

HEIGHT: 20 cm MAXIMUM

SECTION: DIAM. 32 (THE CABINET IS SUPPLIED WITH DRAIN HOSE, DIAM. 32)

L = PLACEMENT OF POWER SUPPLY INPUT

HEIGHT: 250 cm

SECTION: 2,5 MMQ. IF DISTANCE BETWEEN CABINET AND MAIN SWITCH IS LESS THAN 15 MT

STRUCTURE	
Panels	<i>Isothermal (Insulated)</i>
Insulation type	<i>Poliurethane foam injected at high density</i>
Insulation density	<i>42 Kgs/mc</i>
Insulation thickness	<i>80 mm</i>
Panels' connection	<i>Dual action eccentric hooks</i>
Inner panels' corners	<i>Entirely rounded</i>
Inner panels' base corners	<i>Rounded, injected in the floor</i>
Inner surface	<i>Rounded with PVC profiles</i>
Outer surface	<i>st/st AISI 304</i>
Ceiling outer surface	<i>Lamplast panels, gray color</i>
Rack-bumper on inner perimeter	<i>st/st AISI 304</i>
Window to inspect the product	<i>N° 1 for door</i>
Rack-bumper on inner perimeter	<i>st/st AISI 304</i>
HINGES	
Finishing	<i>Painted, with plastic cover</i>
Self-lifting	<i>To ease the opening and prevent seal wearing</i>
CLOSING SYSTEM	
Mechanism type	<i>Self-closing system (with gas piston)</i>
Handle type	<i>Ergonomic, on door width</i>
Safety opening	<i>Push</i>
AIR DISTRIBUTION	
Flow features	<i>Single-direction with ejection outside product</i>
Horizontal channels	<i>Missing</i>
Vertical channels	<i>Missing</i>
HUMIDITY AND HEATING UNIT	
Structure	<i>st/st AISI 304</i>
Moistening	<i>With submerged armored electric elements</i>
Heating	<i>with armored electric elements</i>
Control / level adjustment	<i>Dedicated electronic card</i>
Humidity range	<i>20% - 99%</i>
Temperature range	<i>Room temperature ÷ +42°C</i>
CONTROL PANEL	
Temperature sensor	<i>Electronic</i>
Humidity sensor	<i>Electronic</i>
Electric board	<i>In compliance with actual rules</i>
Control and display system	<i>Above door with dedicated card</i>
Inner lighth	<i>LED lamps</i>
Control and display system	<i>Multilingual and multifunction display touch-screen with the possibility of interconnection to BAKEAPP 4.0 system (on request)</i>
OPERATION AND PROGRAMS	
Programs	<i>Manual + automatic start, to set day by day</i>
Alarms display	<i>Audible and visual signal with identification code on the display</i>
Alarms log	<i>N°1</i>

TYPE	Overall width A	Overall length B	Useful width	Useful length	Number of doors	Door clearance	Roto racks capacity						Loaders capacity			Power consumption (max)	
							4060	4666	4676	6065	6080	80100	80120	64x230 (L=170)	64x274 (L=214)		64x318 (L=256)
119x139	1190	1390	960	1020	1	960	2	1	1	1	1	1	--	--	--	5,4	
119x159	1190	1590	960	1220	1	960	3	2	2	1	1	1	--	--	--	5,4	
119x179	1190	1790	960	1420	1	960	4	2	2	2	2	1	1	--	--	5,4	
119x199	1190	1990	960	1620	1	960	4	3	3	2	2	1	1	--	--	5,4	
119x219	1190	2190	960	1820	1	960	5	3	3	2	2	1	1	--	--	5,4	
119x239	1190	2390	960	2020	1	960	6	3	3	3	3	1	1	--	--	5,4	
119x259	1190	2590	960	2220	1	960	6	4	4	3	3	2	1	--	--	5,4	
119x279	1190	2790	960	2420	1	960	7	4	4	3	3	2	1	1	--	5,4	
119x299	1190	2990	960	2620	1	960	8	5	5	3	3	2	2	1	--	5,4	
119x319	1190	3190	960	3820	1	960	8	5	5	4	4	2	2	1	1	--	5,4
119x339	1190	3390	960	3020	1	960	9	5	5	4	4	2	2	1	1	--	5,4
119x359	1190	3590	960	3220	1	960	10	6	6	4	4	3	2	1	1	1	5,4
139x139	1390	1390	1160	1020	1	1160	2	2	2	1	1	1	--	--	--	5,4	
139x159	1390	1590	1160	1220	1	1160	4	2	2	1	1	1	--	--	--	5,4	
139x179	1390	1790	1160	1420	1	1160	4	4	3	2	2	1	1	--	--	5,4	
139x199	1390	1990	1160	1620	1	1160	5	4	4	2	2	1	1	--	--	5,4	
139x219	1390	2190	1160	1820	1	1160	6	4	4	2	2	2	1	--	--	5,4	
139x239	1390	2390	1160	2020	1	1160	7	6	5	3	3	2	1	--	--	5,4	
139x259	1390	2590	1160	2220	1	1160	8	6	5	3	3	2	1	--	--	5,4	
139x279	1390	2790	1160	2420	1	1160	8	6	6	3	3	2	1	1	--	5,4	
139x299	1390	2990	1160	2620	1	1160	8	7	6	3	3	3	2	1	--	5,4	
139x319	1390	3190	1160	3820	1	1160	9	8	7	4	4	3	2	1	1	--	5,4
139x339	1390	3390	1160	3020	1	1160	10	8	7	4	4	3	2	1	1	--	5,4
139x359	1390	3590	1160	3220	1	1160	12	9	8	4	4	3	2	1	1	1	5,4
179x139	1790	1390	1400	1020	2	1400	4	4	2	2	2	1	1	--	--	5,4	
179x159	1790	1590	1400	1220	2	1400	5	4	2	2	2	1	1	--	--	5,4	
179x179	1790	1790	1400	1420	2	1400	6	4	4	4	2	1	1	--	--	5,4	
179x199	1790	1990	1400	1620	2	1400	7	6	5	4	4	1	1	--	--	5,4	
179x219	1790	2190	1400	1820	2	1400	9	6	5	6	4	1	1	--	--	5,4	
179x239	1790	2390	1400	2020	2	1400	9	6	6	6	4	2	1	--	--	5,4	
179x259	1790	2590	1400	2220	2	1400	10	8	6	6	4	2	1	--	--	5,4	
179x279	1790	2790	1400	2420	2	1400	11	8	8	6	5	2	2	2	--	11,0	
179x299	1790	2990	1400	2620	2	1400	12	10	8	8	6	2	2	2	--	11,0	
179x319	1790	3190	1400	3820	2	1400	13	10	8	8	6	2	2	2	2	--	11,0
179x339	1790	3390	1400	3020	2	1400	14	10	9	8	7	3	2	2	2	--	11,0
179x359	1790	3590	1400	3220	2	1400	15	12	10	10	7	3	2	2	2	2	11,0

TYPE	Overall width A mm	Overall length B mm	Useful width mm	Useful length mm	Number of doors	Room useful width mm	Roto racks capacity						Loaders capacity			Power consumption (max) kW	
							4060	4666	4676	6065	6080	80100	80120	64x230 (L=170)	64x274 (L=214)		64x318 (L=258)
199x139	1990	1390	1600	1020	2	1600	5	3	3	2	2	1	1	--	--	--	5,4
199x159	1990	1590	1600	1220	2	1600	5	5	4	2	2	1	1	--	--	--	5,4
199x179	1990	1790	1600	1420	2	1600	6	6	5	4	2	1	1	--	--	--	5,4
199x199	1990	1990	1600	1620	2	1600	7	6	6	4	4	1	1	--	--	--	5,4
199x219	1990	2190	1600	1820	2	1600	8	7	7	4	4	2	2	--	--	--	5,4
199x239	1990	2390	1600	2020	2	1600	9	8	7	6	4	2	2	--	--	--	5,4
199x259	1990	2590	1600	2220	2	1600	10	19	8	6	5	2	2	--	--	--	5,4
199x279	1990	2790	1600	2420	2	1600	10	10	9	6	5	2	2	2	--	--	11,0
199x299	1990	2990	1600	2620	2	1600	12	10	9	8	6	3	3	2	--	--	11,0
199x319	1990	3190	1600	3820	2	1600	13	12	10	8	7	3	3	2	2	--	11,0
199x339	1990	3390	1600	3020	2	1600	14	12	10	8	8	3	3	2	2	--	11,0
199x359	1990	3590	1600	3220	2	1600	15	13	12	8	8	3	3	2	2	2	11,0
219x139	2190	1390	1800	1020	2	1800	5	4	4	2	2	2	1	--	--	--	5,4
219x159	2190	1590	1800	1220	2	1800	6	5	4	4	2	2	2	--	--	--	5,4
219x179	2190	1790	1800	1420	2	1800	8	6	5	4	4	2	2	--	--	--	5,4
219x199	2190	1990	1800	1620	2	1800	8	7	6	4	4	2	2	--	--	--	5,4
219x219	2190	2190	1800	1820	2	1800	9	7	7	4	4	2	2	--	--	--	5,4
219x239	2190	2390	1800	2020	2	1800	11	10	7	6	6	4	2	--	--	--	5,4
219x259	2190	2590	1800	2220	2	1800	13	10	8	6	6	4	3	--	--	--	5,4
219x279	2190	2790	1800	2420	2	1800	14	11	9	6	6	4	4	2	--	--	11,0
219x299	2190	2990	1800	2620	2	1800	16	13	11	8	6	4	4	2	--	--	11,0
219x319	2190	3190	1800	3820	2	1800	16	13	12	8	8	4	4	2	2	--	11,0
219x339	2190	3390	1800	3020	2	1800	17	15	12	8	8	4	4	2	2	--	11,0
219x359	2190	3590	1800	3220	2	1800	19	16	14	8	8	6	4	2	2	2	11,0

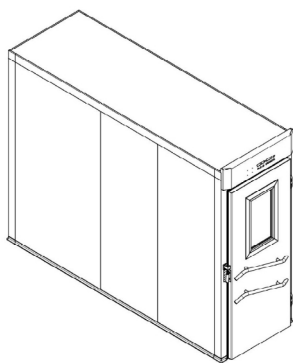

Cabinet height = 2310 mm.
Cabinet height (with power board) = 2580 mm

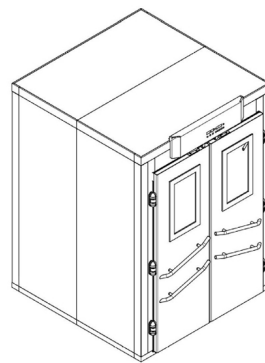

Cabinet height = 2310 mm.
Cabinet height (with power board) = 2580 mm